

PISKO SAFEGRIP ROOF LADDER FOR STANDING SEAM STEEL ROOFS, PISKO UNISEAM

Pisko roof ladders for standing seam roofs are used as extensions of wall-mounted ladders and/or roof walkways to create safe access paths on standing seam roofs. It must be possible to move safely on the roof from the eaves to the ridge, chimney, sunroofs and other areas requiring maintenance. Pisko ladders have a rung width of 400 mm and rung diameter of 25 mm.

INSTALLATION

Roof ladders must be attached to the load-bearing structures of the roof, at least at the top and bottom ends of the ladder (EN 12951, Section 5.3.1). Due to the strain created by snow loads, we recommend the use of more fastenings.

If the ladder is to be extended, the extension must be attached to the top end of the ladder. Secure the joint with M8x40 hexagon bolt and M8 hexagon nut (figure 6).

You will need the following for the installation: Pisko UniSeam roof ladder central fasteners for the ladder's top and bottom ends, roof ladder fasteners for the sides of the ladder frame, as a support solution, and tightening clamps for UniSeam central fasteners.

- Place the EPDM Rubber sealants at the base of the roof ladder fasteners (figure 5).
- Attach the roof ladder fasteners with one M8x30 hexagon bolt to the ladder frame (figure 5).
- Install the roof ladder fasteners in their places on the ladder frame, with intervals of max. 1400 mm (figure 1).
- Install the roof ladder's central fasteners at least on the top and bottom ends of the ladder. Fold the mounting flanges of the central fastener in their positions.
- The maximum distance between central fasteners is 5000 mm (figure 1).
- Attach the central fastener to the rungs with four M8x30 hexagon bolts (figure 5).
- Install the central fastener to the roof seam with Tightening clamps. The tightening clamps are inserted into the holes in the central fastener. The central fastener is mounted to the snap-lock standing seam roofs on the full side of the seam (Figure 2) and to the tinsmith standing seam roofs on the folded side of the seam (figure 3). **NB! The bolt of tightening clamp must always be against the fastener, NOT against the seam (figure 7).**
- Tightening torque of the M8x30 fastening bolt is 30 N/m. Correct tightening torque will spread out the tightening clamp a bit, in order to create a tight long-lasting connection (figure 4).
- The central fastener should be installed at a minimum distance of 100 mm from the side rail.

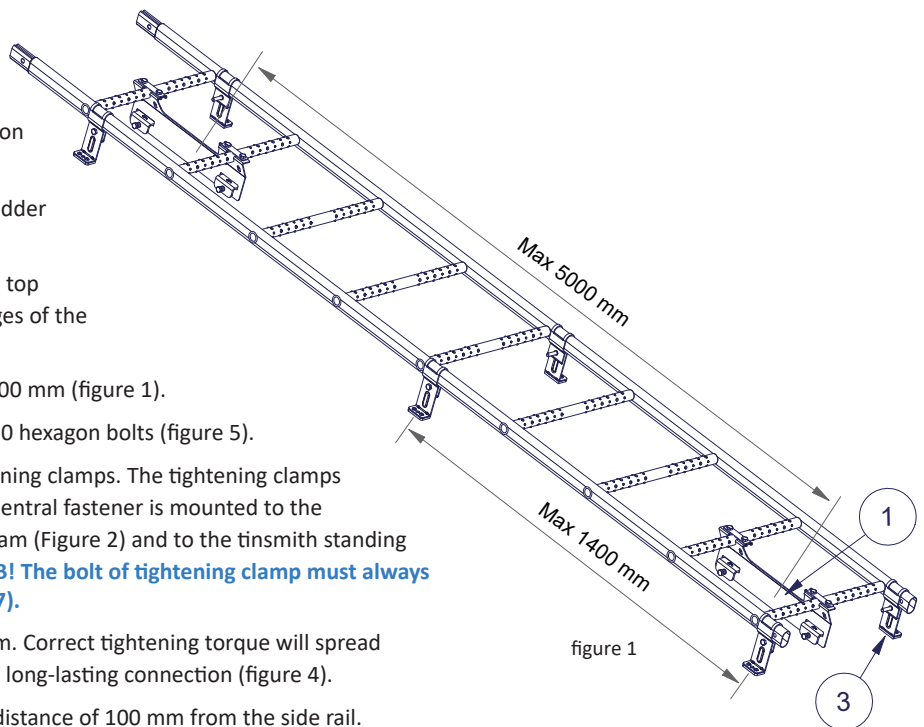

figure 1

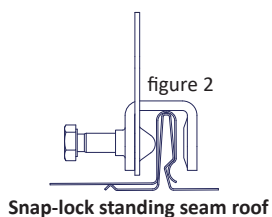

figure 2

Snap-lock standing seam roof

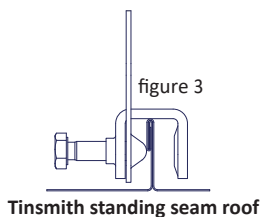

figure 3

Tinsmith standing seam roof

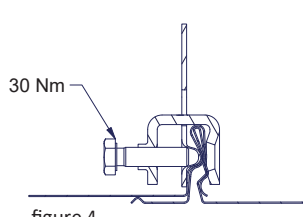

figure 4

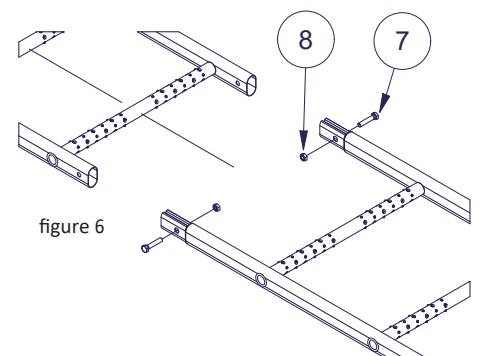

figure 6

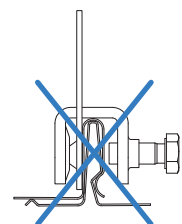

figure 7

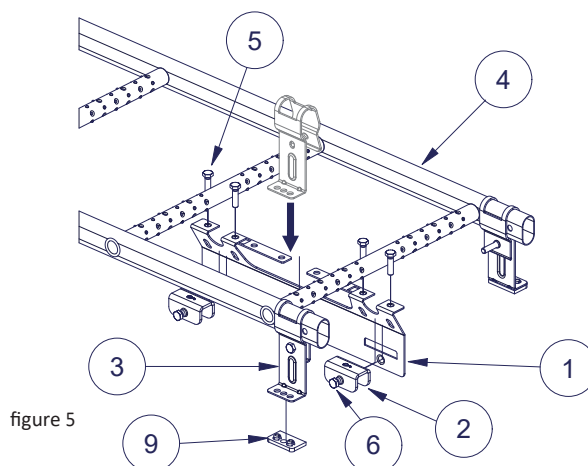

figure 5

Part	Description
1	Central fastener, Pisko UniSeam
2	SG Tightening Clamp, Pisko UniSeam
3	Roof ladder fastener
4	Pisko SafeGrip ladder
5	Hexagon bolt M8x30, hot-dip galvanized
6	Hexagon bolt M8x35, hot-dip galvanized
7	Hexagon bolt M8x40, hot-dip galvanized
8	Hexagon nut M8, hot-dip galvanized
9	Roof ladder rubber seal

USE

Roof ladder must be used when the roof inclination is more than 1:8. If the height of the building is more than 9 meters, safety rope fixing structures must be provided (Ministry of the Environment Decree on the safe use of buildings on January 1, 2018). Standard EN 12951 provides two installation options for roof ladders: class 1 and class 2. Using personal fall protection equipment, a person is only allowed to attach themselves to a roof ladder, which is installed in accordance with class 2. Pisko SafeGrip roof ladder has been dimensioned against 1,5 kN (~150 kg) concentrated load (load from the user).

The Pisko SafeGrip roof ladder for standing seam roof conforms to standard EN 12951, having undergone static and dynamic tests per class 2. An appropriate safety rope can be fixed to a roof ladder, which is installed in accordance with class 2. The safety rope must be intended to be used as a personal safety rope and it must conform to relevant standards such as e.g. EN 353-2 and should be equipped with a shock absorber (EN 355). Moreover, the following must be taken into consideration when using a safety rope:

- Only safety ropes (e.g. EN 353-2) or retractable lanyards (EN 360) that are meant to be used as a personal fall protection equipment should be used
- The recommended safety rope fixing point is the side stile of the ladder
- Only one person at a time, with a total weight of max. 100 kg, including the equipment, is allowed to fix a safety rope to the roof ladder.
- The safety rope must be fixed to the roof ladder only in the space between the roof ladder fasteners, that connect the ladder to the roof structure.
- The safety rope shall never be fixed to the support foots of the ladder
- The safety rope may only be used towards the eave on the pitched roof area where the roof ladder is installed.

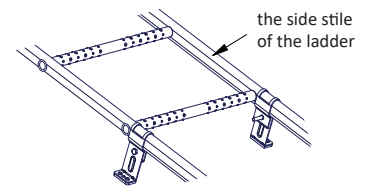

MAINTENANCE

Pisko products are hard-wearing and safe to use, guaranteed by the ongoing quality control and development work by Piristeel Ltd, as well as correct installation of the products according to the manufacturer's instructions. To ensure the reliability and safety of the products, the property owner must carry out yearly inspection and maintenance procedures, and monitor that the snow load specified by the regulations is not exceeded.

The property owner must have all roof safety products, that have been installed and used according to class 2, and personal safety equipment inspected by a professional authorized by the manufacturer.

Yearly maintenance inspection checklist for Pisko products:

- Check the tightness of joints, connections and attachments.
- Check the roof attachments (fixings).
- Ensure any excessive snow load is cleared to minimize the strain on structures and attachment points (as necessary; there might be a need several times during the winter).
- As necessary, clear the roof ladders of snow and ice.
- Check the paintwork and zinc coating of the products; repair faults and touch up paintwork if necessary
- Replace or repair any damaged or faulty parts as soon as possible.

CE
Piristeel Oy Metallitie 4, 62200 Kauhava Finland 20
EN 12951 Pisko SafeGrip roof ladder with roof ladder fastener, Pisko UniSeam 1364 TB Mechanical strength: Class 1 and Class 2 Reaction to fire: Class A1 Durability: Z275 + powder coating 80 µm External fire performance: DTS

This product has been installed by

- According to class 1:
- According to class 2:

COMPANY

INSTALLER